

ONSIOW COUNTY

LOCATION: 1 SECTION OF SECONDARY ROAD

TYPE OF WORK: MILLING, RESURFACING & SIGNAL MODIFICATION

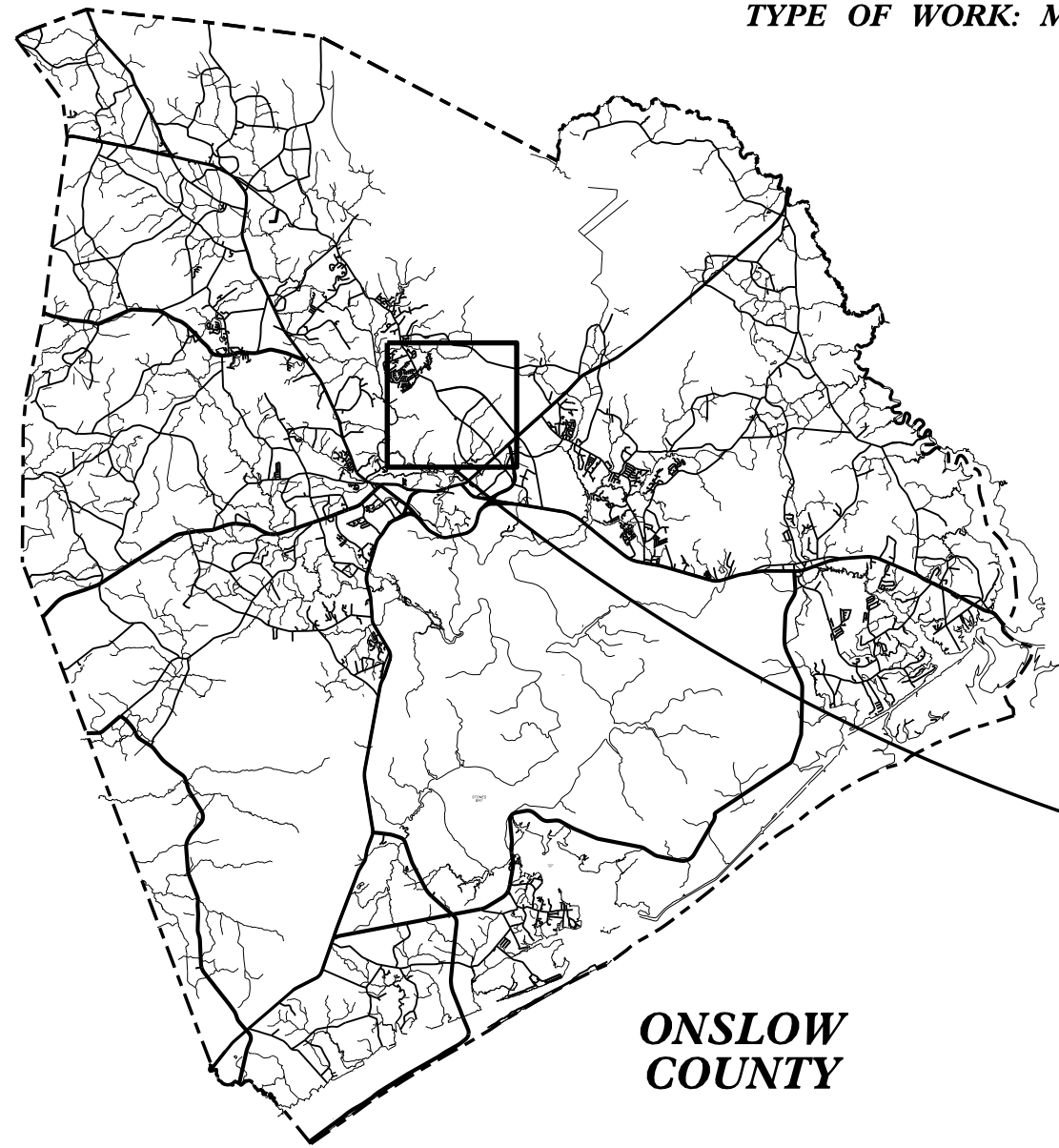

**ONSIOW
COUNTY**

INDEX OF SHEETS	
SHEET NO.	SHEET
1	VICINITY MAP
2 - 10	PAVEMENT SCHEDULE, TYPICAL SECTIONS & DETAIL SHEETS
11	TRAFFIC CONTROL DETAIL
SIG-1	SIGNAL PLANS

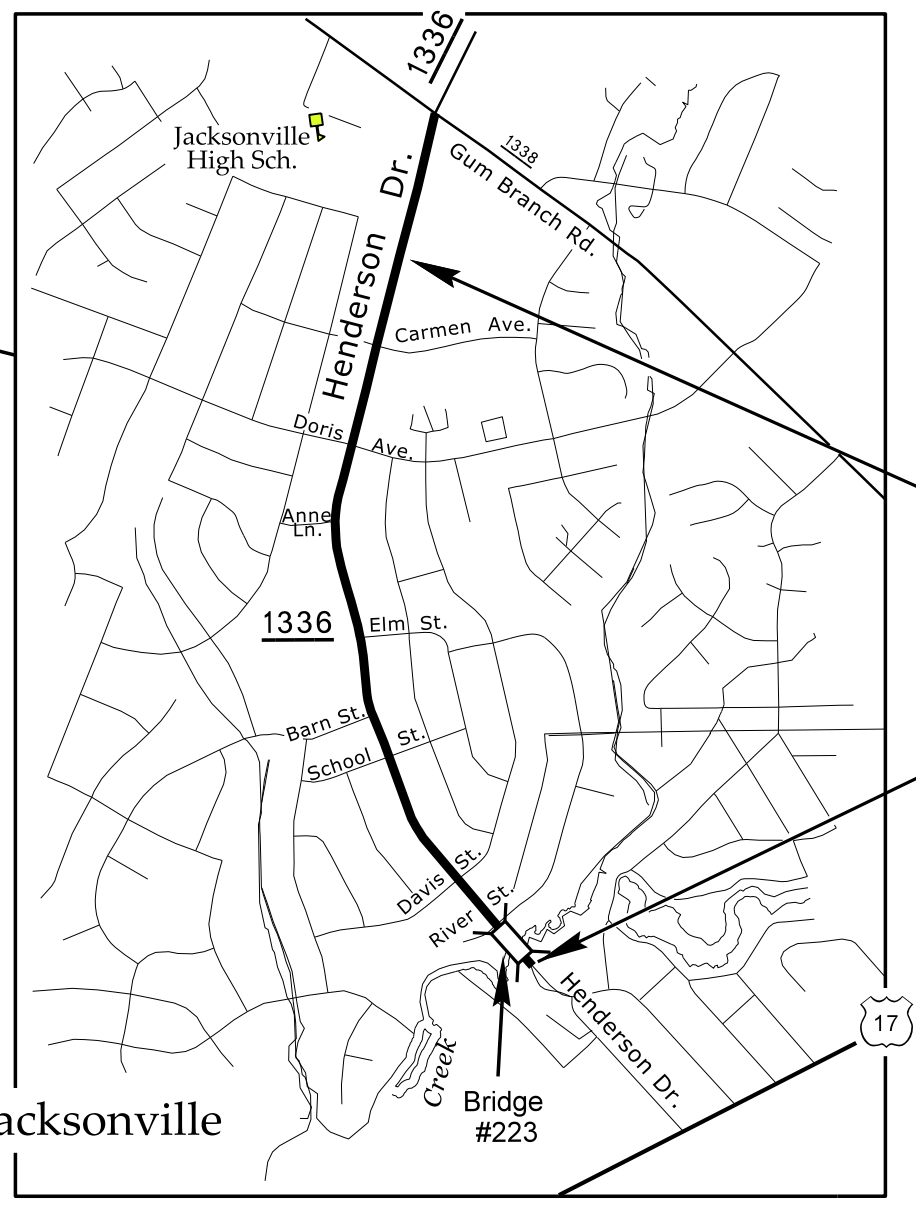

**SR 1336
Henderson Dr.**

1

Jacksonville

MAPS N.T.S.

REVISIONS

27-JAN-2020 15:20
 S:\Division\Resurfacing\Resurfacing Data\2021\Resurfacing\ONSLOW\SR_1336-Henderson_Dr_Resurfacing\2021CPT.03.01.20671_Red_tah_MPK.dgn
 \$\$\$SUSPENSE\$\$\$

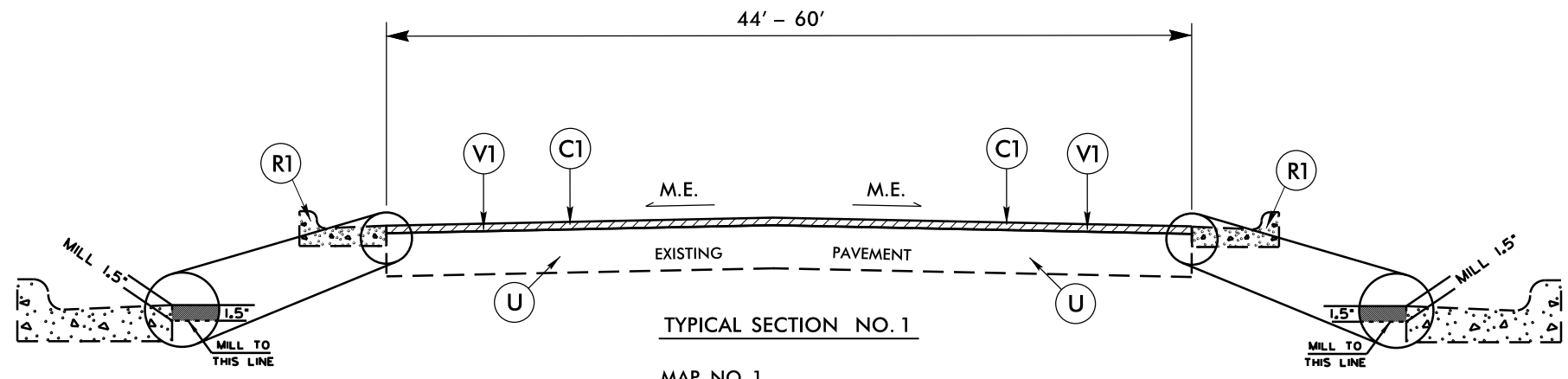

TYPICAL SECTION NO. 1

MAP NO. 1
SR 1336 (HENDERSON DR.)
MP 1.33 - MP 2.57

(NO ASPHALT WORK:
ON SLOW BRIDGE NO. 223
MP 2.54 - MP 2.56)

CONSTRUCTION SEQUENCE:

- ONLY ONE LANE SHALL BE CLOSED AT A TIME:
- MILL ENTIRE SINGLE LANE AT 1.5" DEPTH
- PATCH EXISTING PAVEMENT (FULL DEPTH)
- B25.0C (2 LIFTS 4" EACH)
- RESURFACE S9.5B (1 LIFT 1.5" DEPTH)

NOTES: -Y- LINE TIE-INS WILL BE MILLED 1.5" AND RESURFACED 1.5" WITH S9.5B.

SEE SIGNAL PLANS FOR LOOP REPLACEMENTS & PAVEMENT MARKINGS AT DORIS AVE. INTERSECTION.

PAVEMENT SCHEDULE	
C1	PROP. APPROX. 1½" DEPTH ASPHALT CONCRETE SURFACE COURSE, TYPE S9.5B, AT AN AVERAGE RATE OF 165 LBS. PER SQ.YD.
E1	PROP. APPROX. 8" DEPTH ASPHALT CONCRETE BASE COURSE, TYPE B25.0C, AT AN AVERAGE RATE OF 456 LBS. PER SQ.YD. IN EACH OF TWO LAYERS
R1	EXISTING CONCRETE 2'-6" CURB & GUTTER
U	EXISTING PAVEMENT
V1	MILLING ASPHALT PAVEMENT, 1½" DEPTH

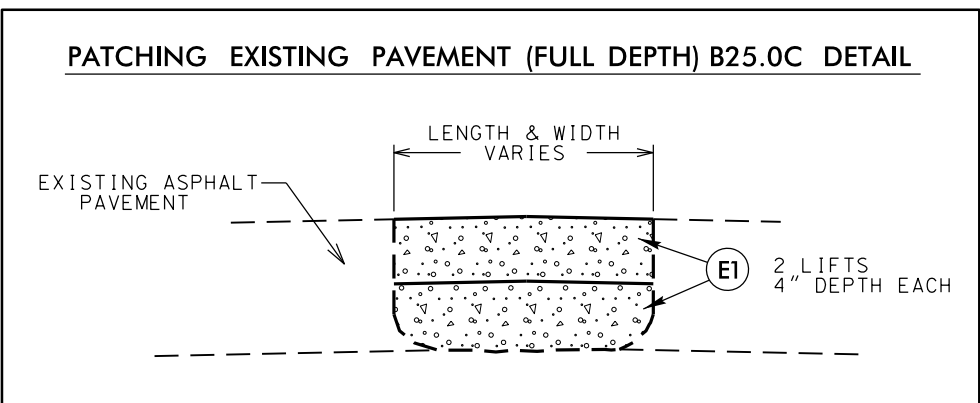

USE DETAIL FOR MAP 1 - SR 1336 (HENDERSON DR.)

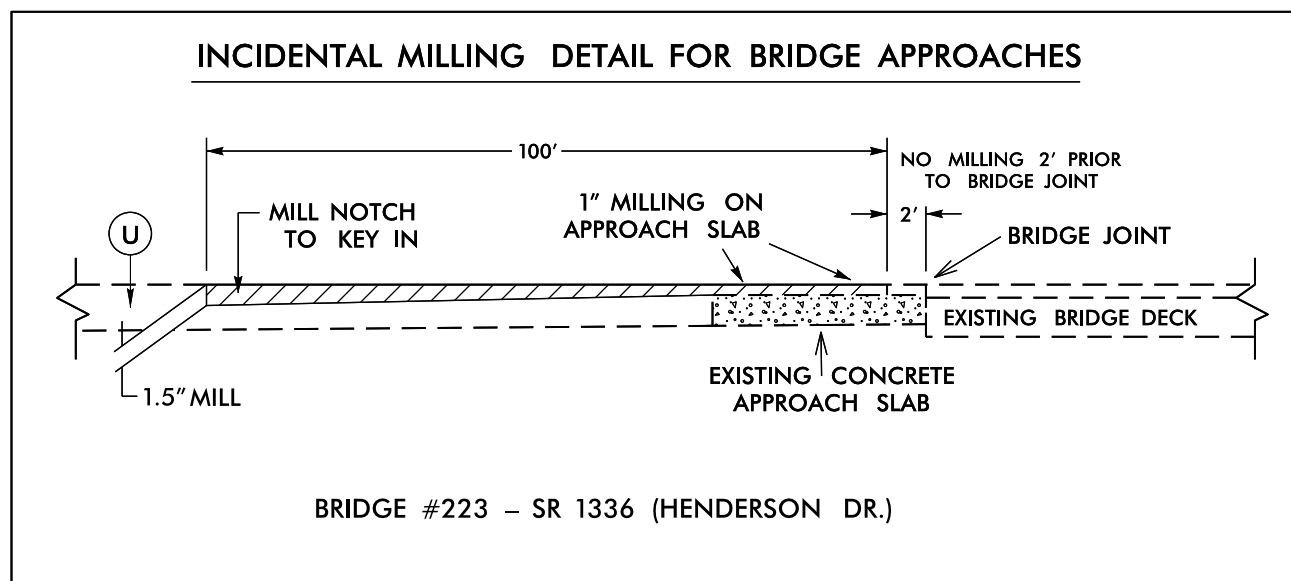

BRIDGE #223 - SR 1336 (HENDERSON DR.)

REVISIONS

30-JAN-2020_08:04
 S:\Division\Resurfacing\Resurfacing Data\2021\Resurfacing\ONSLow\SR_1336_Henderson_Dr_Resurfacing\2021CPT.03.01.20671_Red_ytah_MPK.dgn
 \$\$\$\$\$\$\$\$\$\$

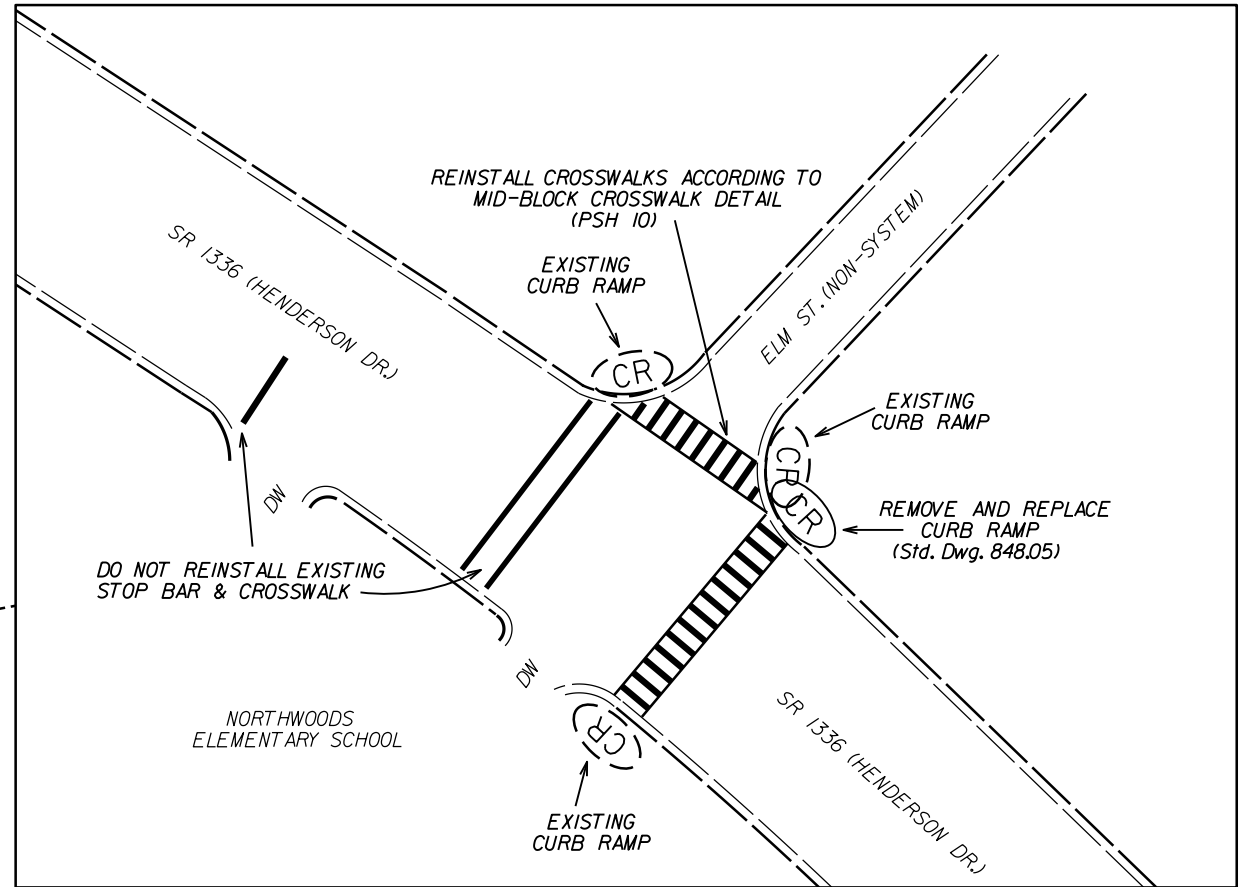
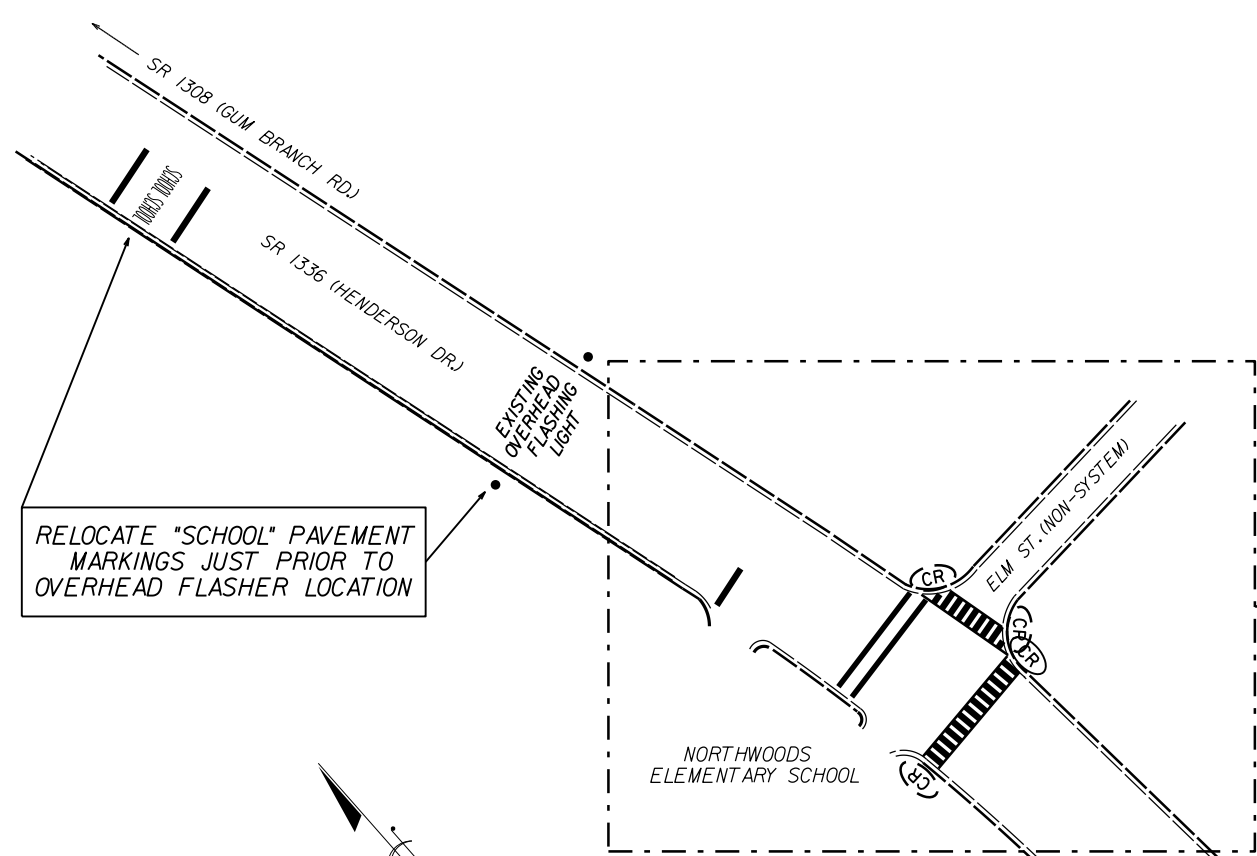

SR 1336 (HENDERSON DR.) & ELM ST. DETAIL

EFF.01-16-2018
REV.

2018 ROADWAY ENGLISH STANDARD DRAWINGS

The following Roadway Standards as appear in "Roadway Standard Drawings" Highway Design Branch - N.C. Department of Transportation - Raleigh, N.C., Dated January, 2018 are applicable to this project and by reference hereby are considered a part of these plans:

STD.NO.	TITLE
DIVISION 8 - INCIDENTALS	
846.01	Concrete Curb & Gutter
848.01	Concrete Sidewalk
DIVISION 12 - PVTM MARKING, MARKERS AND DELINEATION	
1205.08	Pavement Markings - Symbols & Word Messages

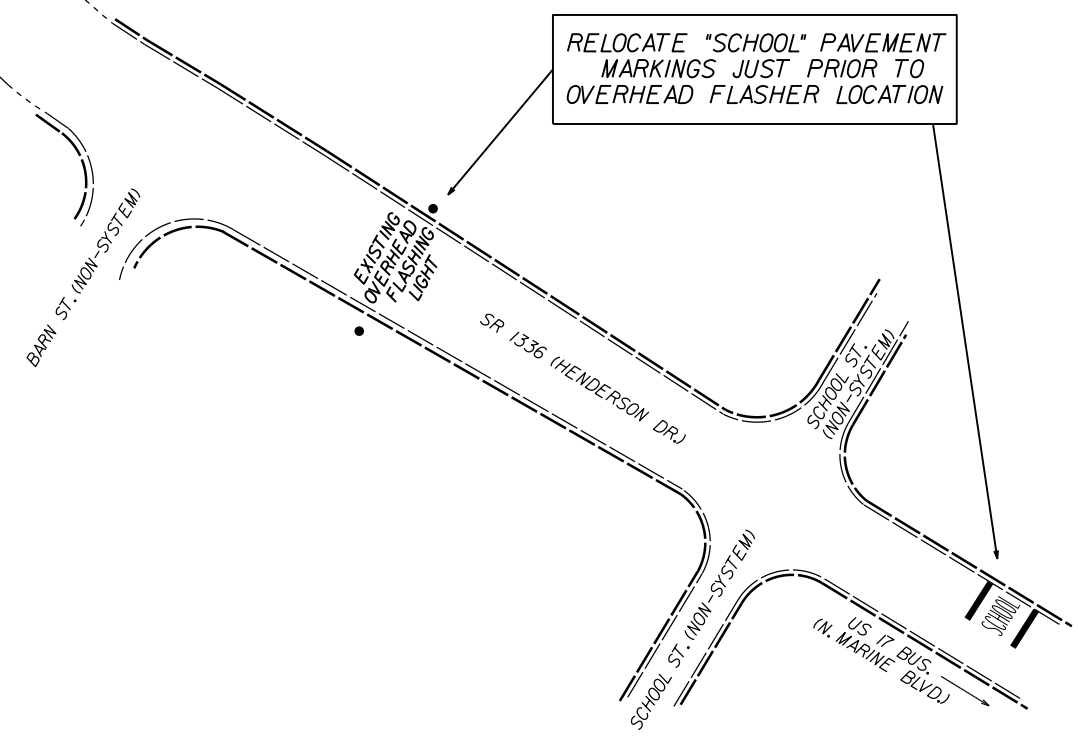

5/14/99
 27-JAN-2020 13:40
 p:\p\2021\03\01\20671\RDY.tsh MPK.dgn
 2021CPT.03.01.20671.RDY.tsh MPK.dgn

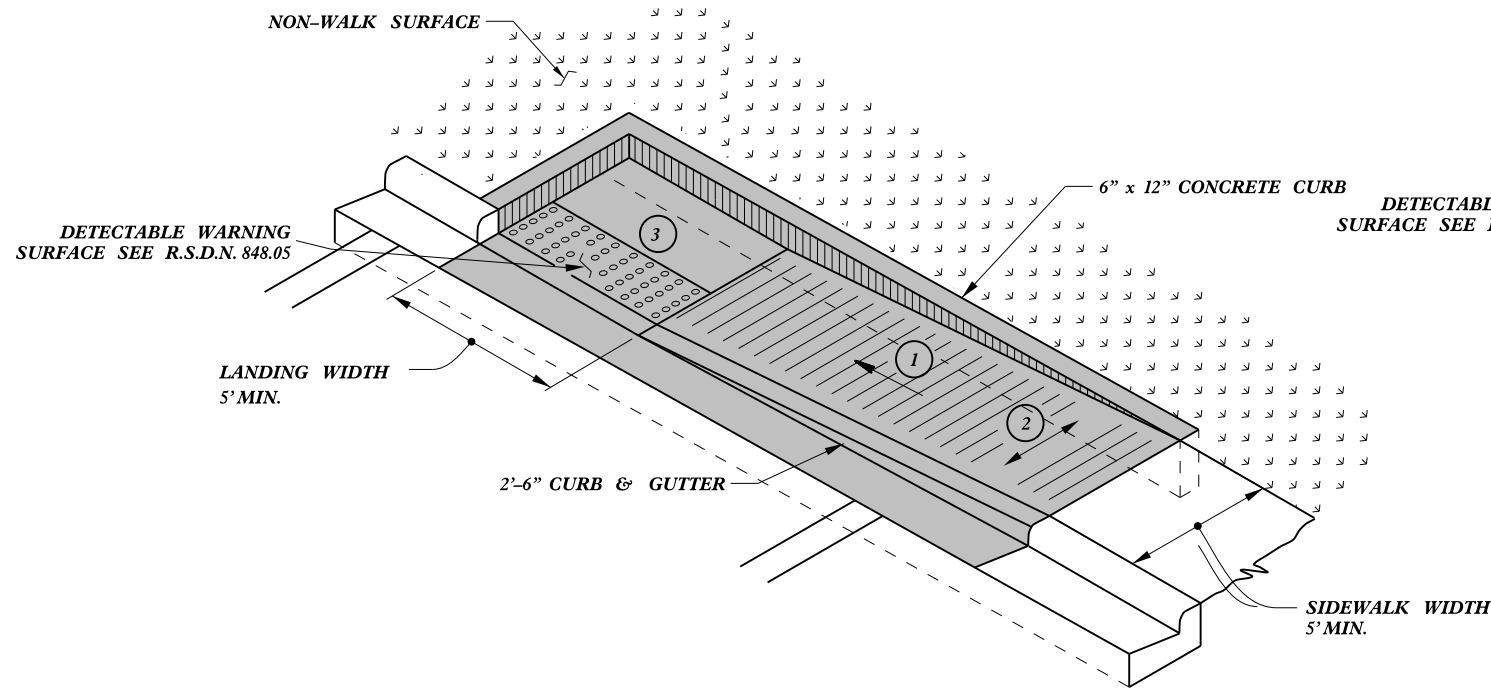

TYPE 1A

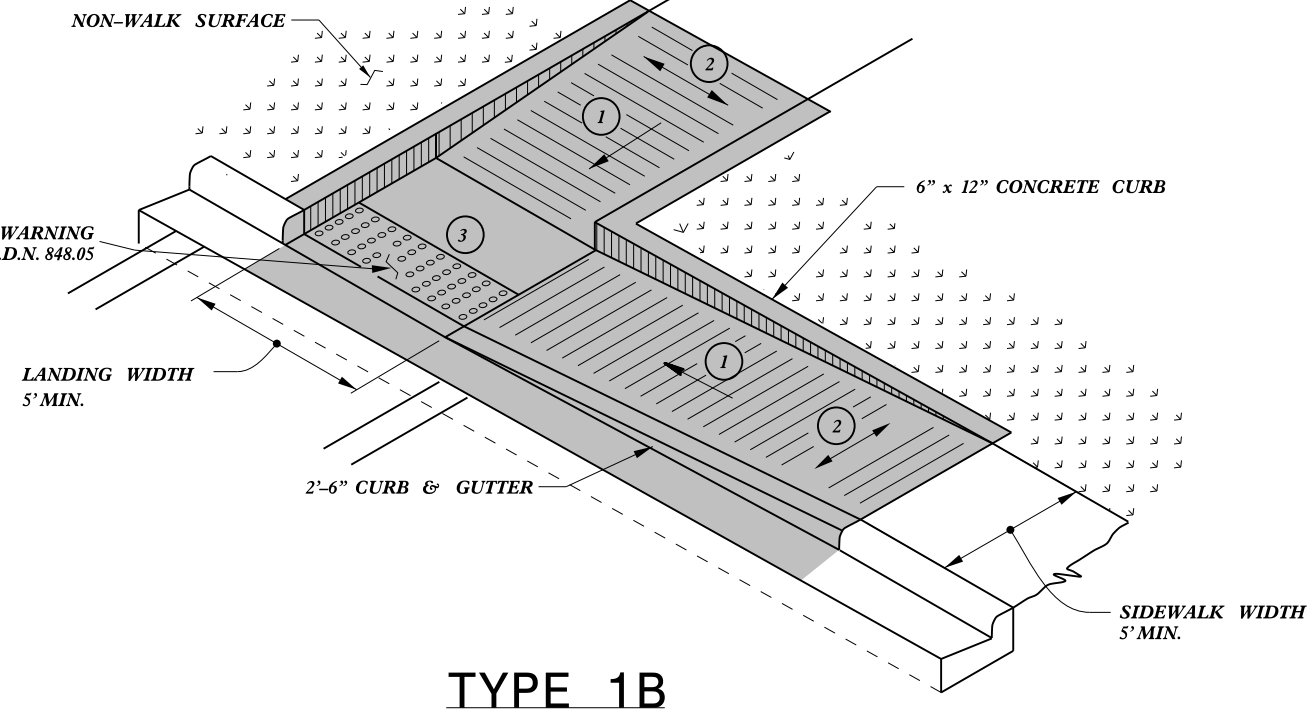

TYPE 1B

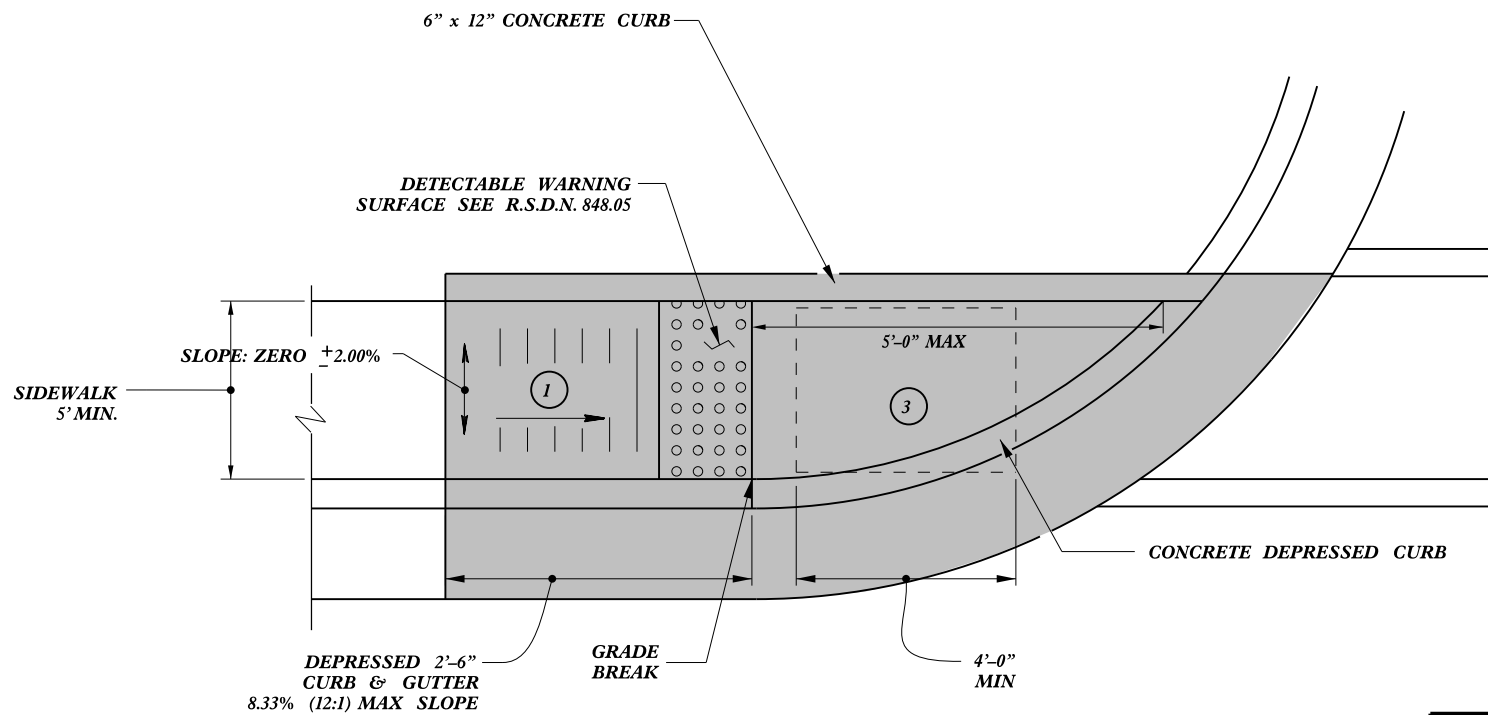

TYPE 1

PAY LIMITS FOR 1 CURB RAMP

- 1 8.33% (12:1) MAX RAMP SLOPE
- 2 CROSS SLOPE: 2.00%
- 3 CURB RAMPS REQUIRE A (4'-0") MINIMUM LANDING WITH A MAXIMUM CROSS SLOPE AND LONGITUDINAL SLOPE OF 2.00% WHERE PEDESTRIANS PERFORM TURNING MANEUVERS. SLOPE TO DRAIN TO CURB.

REFER TO ROADWAY STANDARD DRAWING NUMBER 848.05 SHEET 3 OF 3 FOR ALL RAMP NOTES



DocuSign by
Joel S. Howerton

449E8E25522144F...

11/18/2015

DOCUMENT NOT CONSIDERED FINAL UNLESS ALL SIGNATURES COMPLETED

CONTRACT STANDARDS AND DEVELOPMENT UNIT
Office 919-707-6950 FAX 919-250-4119

CURB RAMPS
Directional Ramps

ORIGINAL BY: J.S. HOWERTON DATE: 7/7/11
MODIFIED BY: _____ DATE: _____
CHECKED BY: _____ DATE: _____
FILE SPEC: stds/2012CurbRamp/CurbRampDetails.dwg

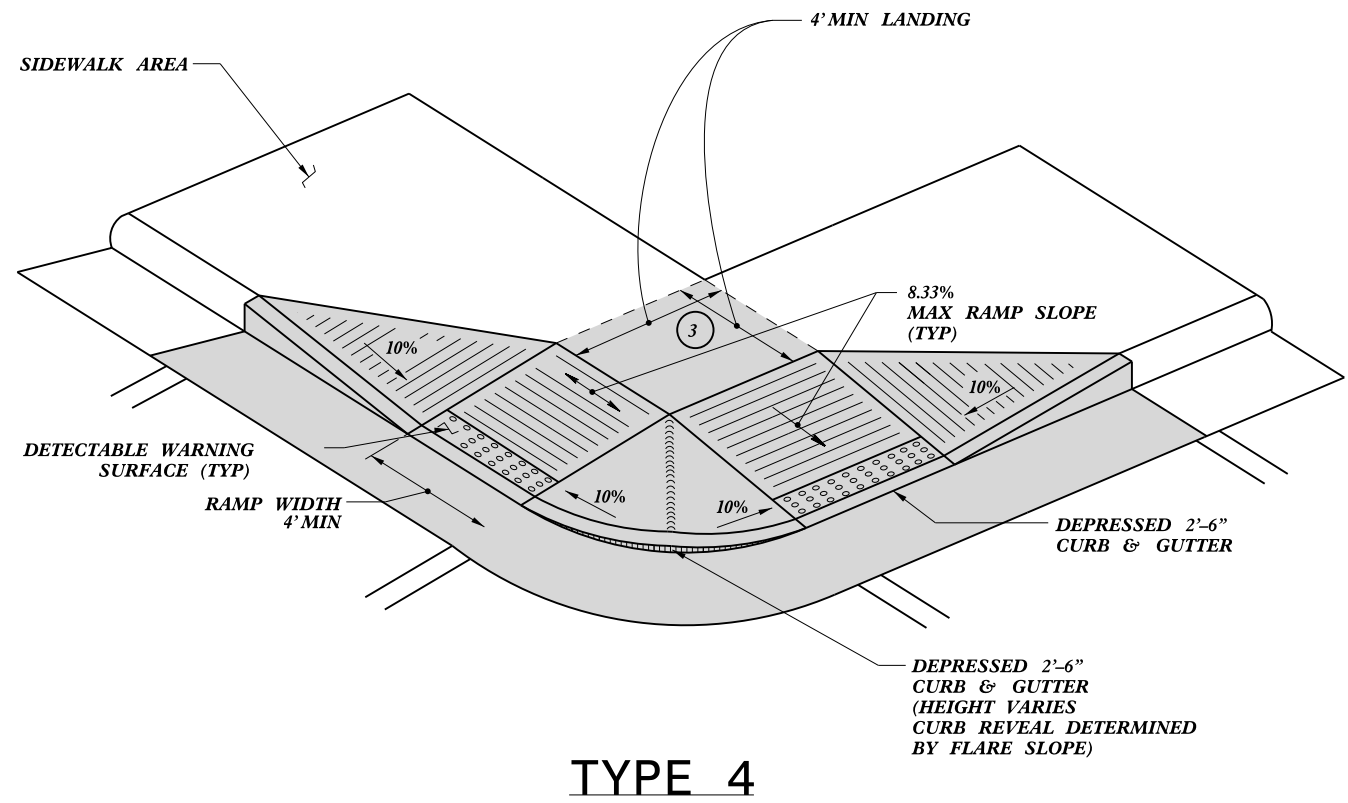

TYPE 4

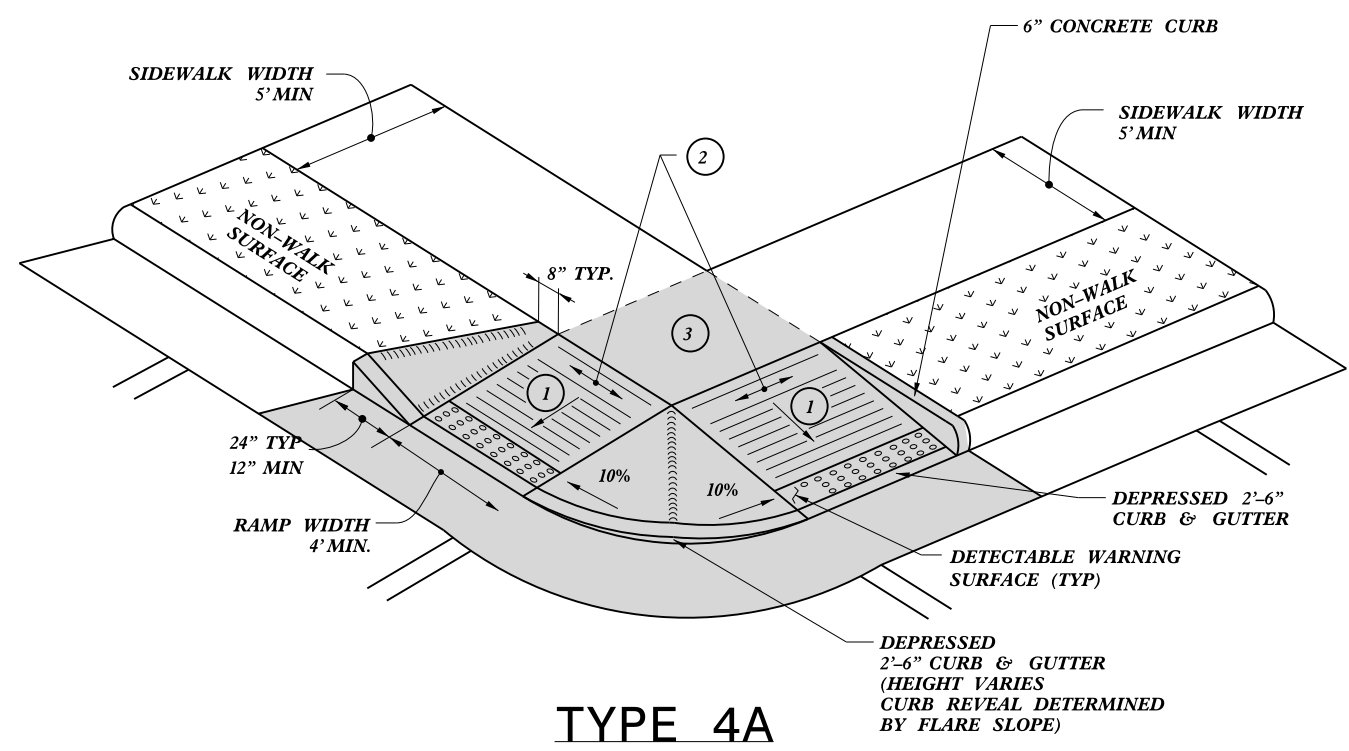

TYPE 4A

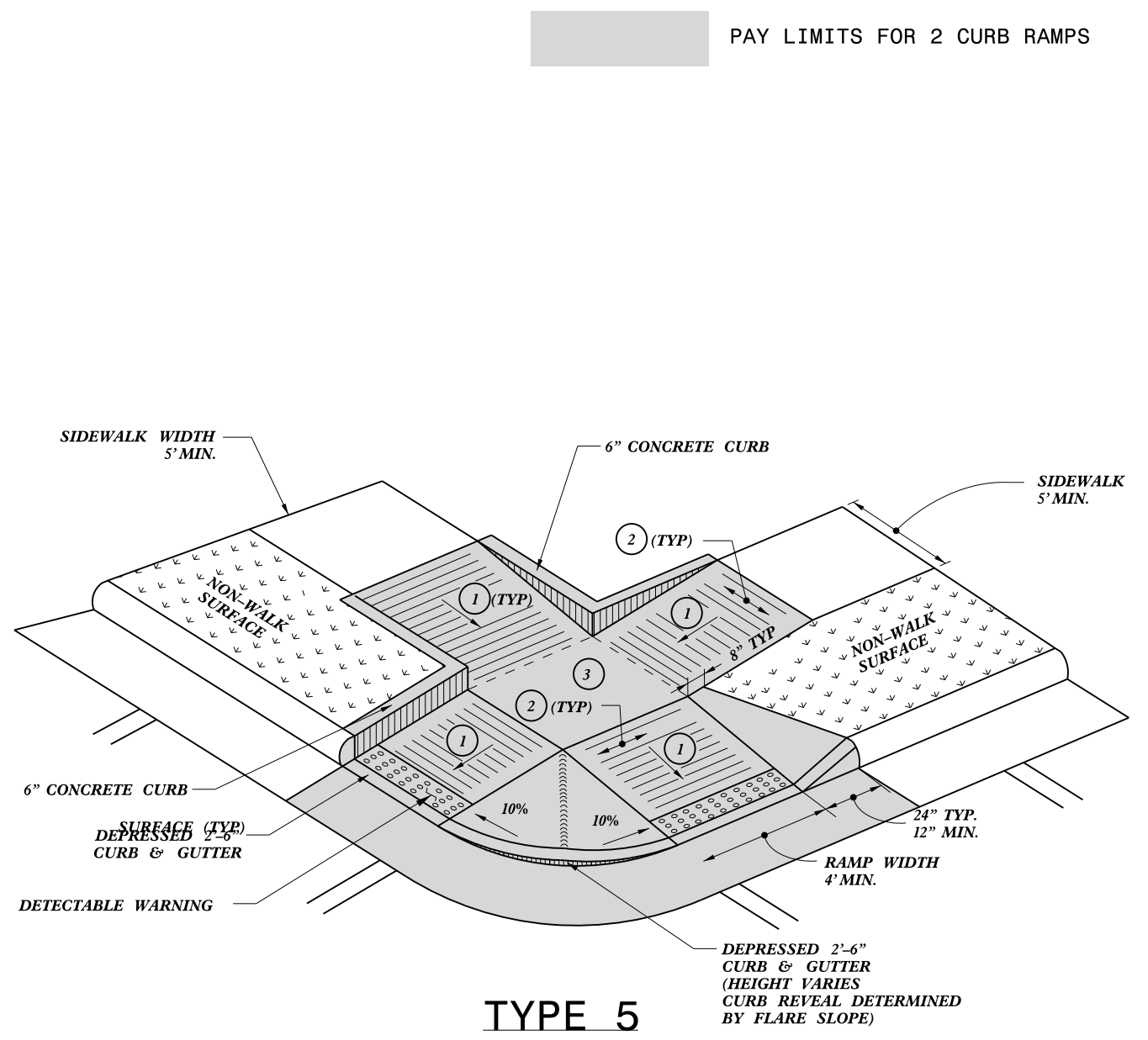

TYPE 5

- 1 8.33% (12:1) MAX RAMP SLOPE
- 2 CROSS SLOPE: 2.00%
- 3 CURB RAMPS REQUIRE A (4'-0") MINIMUM LANDING WITH A MAXIMUM CROSS SLOPE AND LONGITUDINAL SLOPE OF 2.00% WHERE PEDESTRIANS PERFORM TURNING MANEUVERS. SLOPE TO DRAIN TO CURB.

PAY LIMITS FOR 2 CURB RAMPS

DocuSigned by:
Joel S Howerton
449E8E25522144F...



11/18/2015

DOCUMENT NOT CONSIDERED FINAL UNLESS ALL SIGNATURES COMPLETED

CONTRACT STANDARDS AND DEVELOPMENT UNIT	
Office 919-707-6950	FAX 919-250-4119
CURB RAMPS	
Shared Landing	
ORIGINAL BY: J.S. HOWERTON	DATE: 7/7/11
MODIFIED BY:	DATE:
CHECKED BY:	DATE:
FILE SPEC: stds/2012CurbRamp/CurbRampDetails.dwg	

REFER TO ROADWAY STANDARD DRAWING NUMBER 848.05 SHEET 3 OF 3 FOR ALL RAMP NOTES

5/14/99
SYTIME/CON/US/STANDARD/NAME/25

STATE OF NORTH CAROLINA
DEPT. OF TRANSPORTATION
DIVISION OF HIGHWAYS
RALEIGH, N.C.

ENGLISH TYPICAL DRAWING FOR
PAVEMENT MARKINGS
HI-VISIBILITY CROSSWALKS
NO-TRACK MARKING GUIDANCE

STATE OF NORTH CAROLINA
DEPT. OF TRANSPORTATION
DIVISION OF HIGHWAYS
RALEIGH, N.C.

ENGLISH TYPICAL DRAWING FOR
PAVEMENT MARKINGS
HI-VISIBILITY CROSSWALKS
NO-TRACK MARKING GUIDANCE

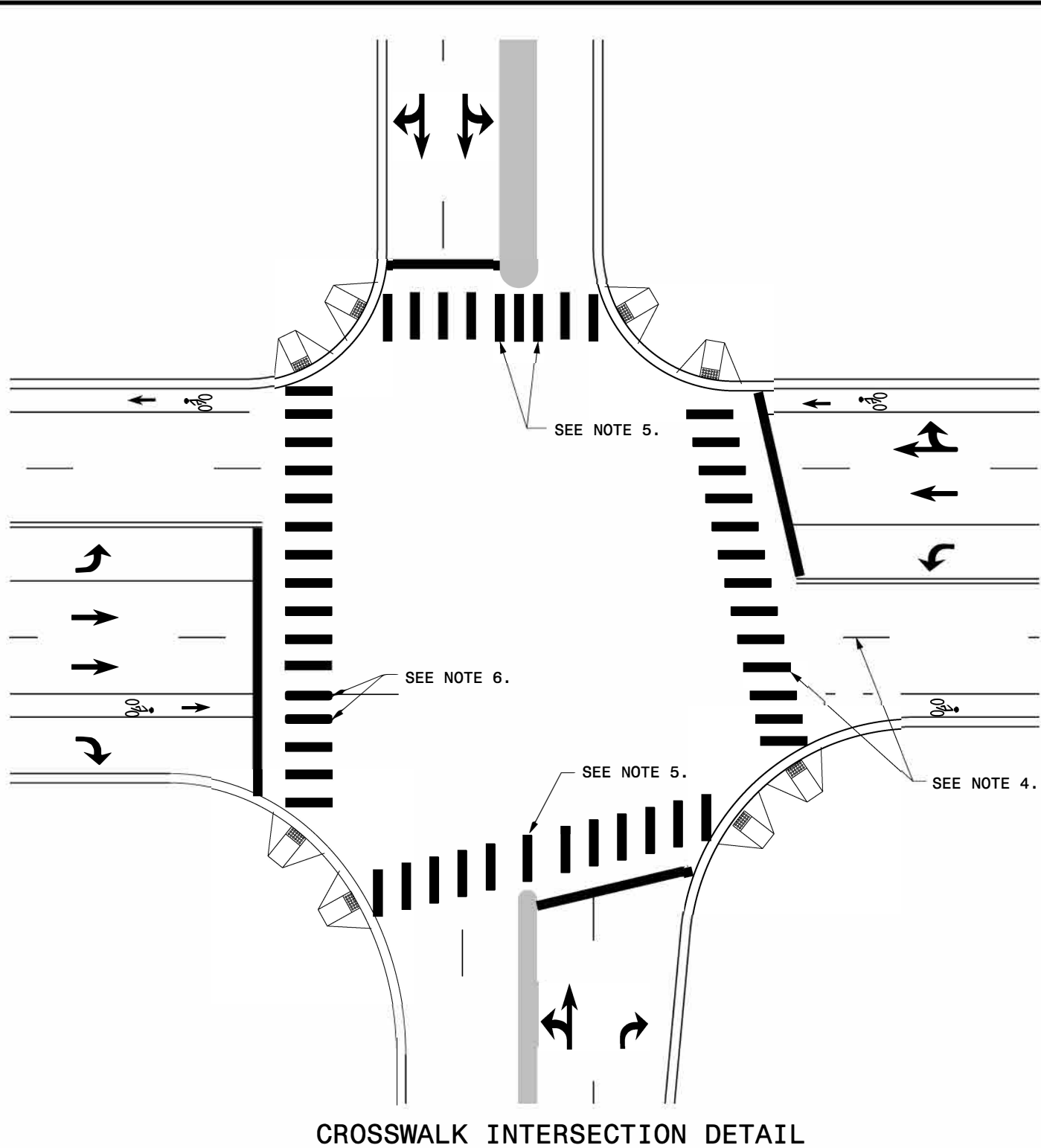

CROSSWALK INTERSECTION DETAIL

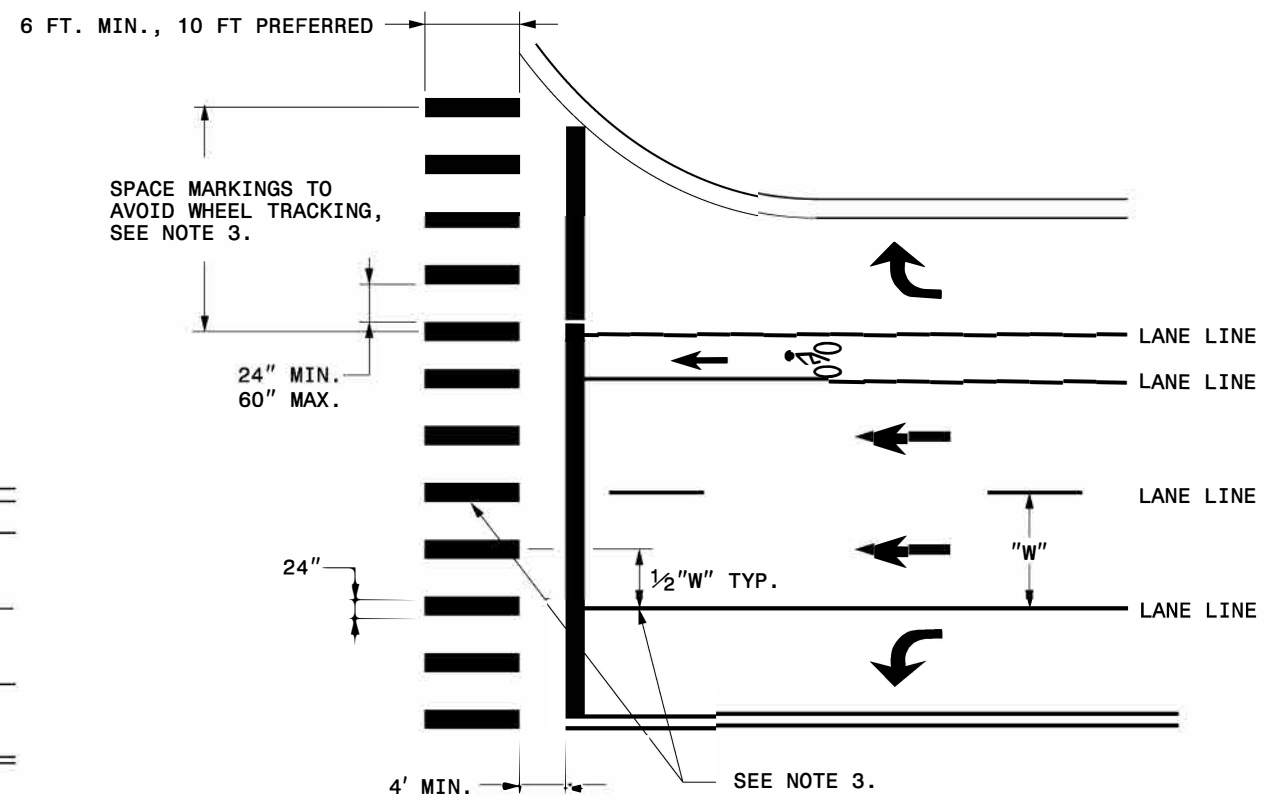

CROSSWALK MARKING DETAIL

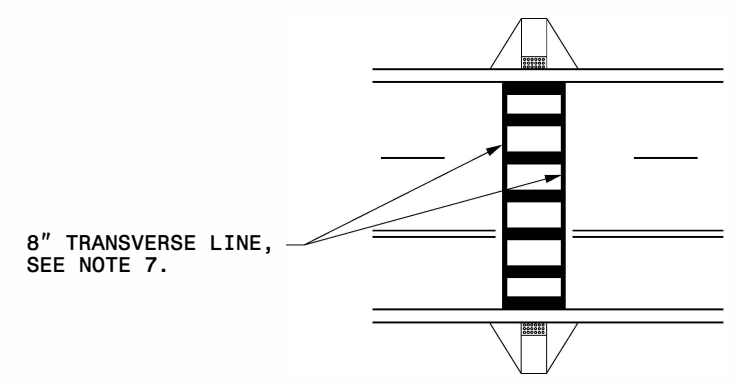

MID-BLOCK CROSSWALK DETAIL

GENERAL NOTES:

- 1- THE GUIDANCE IN THIS DETAIL IS TO BE USED WHEN NO-TRACK SPACING OF HI-VISIBILITY MARKINGS IS REQUESTED.
- 2- USE THE GUIDANCE SHOWN ON THE ABOVE DETAILS IN CONJUNCTION WITH PAVEMENT MARKING GUIDANCE SHOWN ON ROADWAY STANDARD DRAWINGS 1205.01 AND 1205.07.
- 3- PLACE MARKINGS TO AVOID WHEELPATH OF VEHICLES. MARKINGS TYPICALLY WILL BE LOCATED CENTERED AT THE LANE LINES AND EDGE LINES WITH ONE ADDITIONAL MARKING CENTERED IN THE MIDDLE OF THE LANE. AT WIDE LANE WIDTHS DUE TO TAPERS AND LARGE RADII, LOCATE MARKINGS AT BEST SPACING TO AVOID WHEEL TRACKING. THE SPACE BETWEEN MARKINGS SHALL NOT BE LESS THAN 24 INCHES OR GREATER THAN 60 INCHES.

- 4- WHERE THE CROSSWALK IS SKEWED TO THE LANE LINES, THE MARKINGS SHOULD BE PARALLEL TO THE LANE LINES.
- 5- PLACE MARKINGS ON BOTH EDGES OF THE NOSE OF A MEDIAN. FOR NARROW MEDIANS LESS THAN 4 FEET, A SINGLE MARKING MAY BE USED. FOR WIDE MEDIANS, INSTALL ADDITIONAL MARKINGS IN THE MEDIAN AREA. THE SPACE BETWEEN THE MARKINGS SHALL NOT TO BE LESS THAN 24 INCHES OR GREATER THAN 60 INCHES.
- 6- LOCATE MARKINGS CENTERED ON BICYCLE LANE LINES. MARKINGS SHALL NOT BE LOCATED IN THE CENTER OF THE BICYCLE PATH.
- 7- INCLUDE 8" TRANSVERSE LINES WITH 24" LONGITUDINAL MARKINGS AT MID-BLOCK CROSSINGS.

URBAN / SUBURBAN WORKZONES

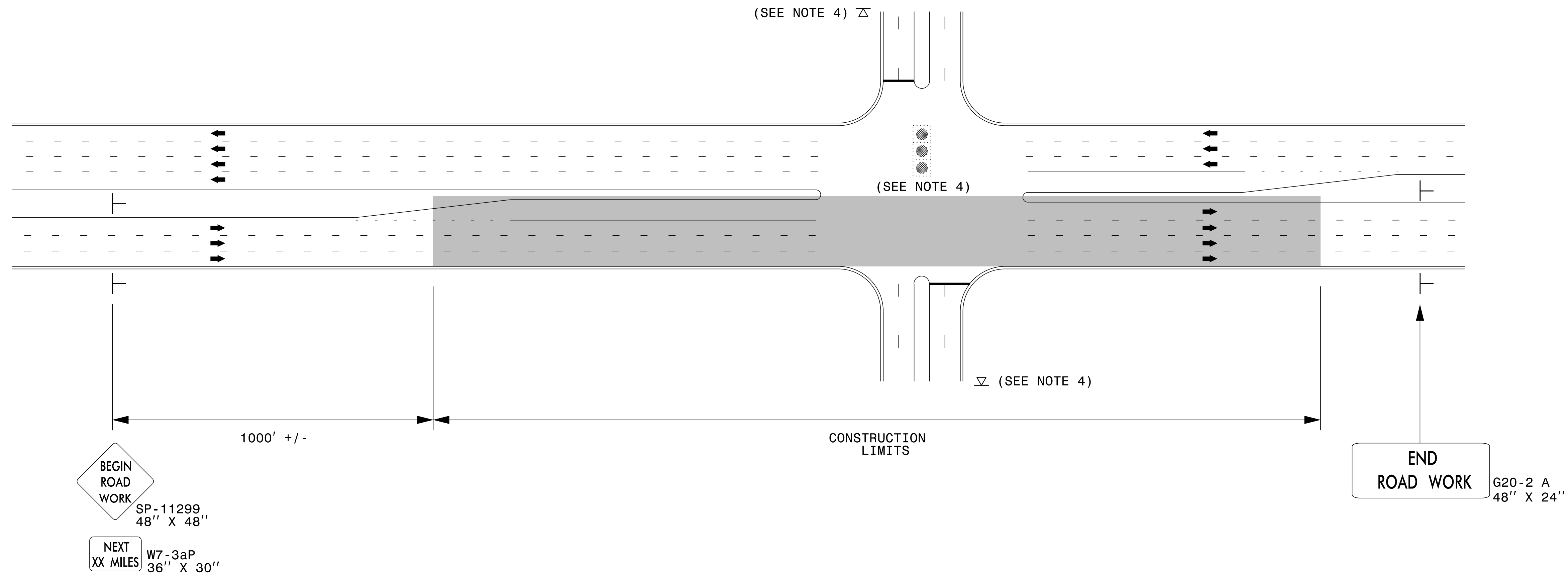

NOTES:

- 1) 48" x 48" SIZED SIGNS (SP- 11299) MAY BE REDUCED TO 36" X 36" ON ROADWAYS WITH SPEED LIMITS OF 40 MPH OR LESS.
- 2) MOUNT SIGNS THAT ARE LARGER THAN 10 SQUARE FEET IN AREA ON TWO OR MORE WOOD OR U-CHANNEL SUPPORTS. PERFORATED SQUARE TUBING SUPPORT SYSTEMS MAY SUPPORT LARGER AREAS ON A SINGLE SUPPORT. FOLLOW MANUFACTURER'S RECOMMENDATIONS. THESE SYSTEMS SHALL BE NCHRP 350 COMPLIANT AND NCDOT APPROVED.
- 3) ADVANCE WARNING SIGNS NOT REQUIRED ON NON-SIGNALIZED SIDE STREETS.
- 4) MAY USE LAW ENFORCEMENT TO CONTROL TRAFFIC AT SIGNALIZED INTERSECTIONS AS DIRECTED BY THE ENGINEER. PROVIDE PORTABLE "ROAD WORK AHEAD" (W20-1) SIGNS 500' IN ADVANCE ALONG BOTH APPROACHES FROM THE SIDE STREETS WHEN PAVING PROCEEDS THROUGH THE INTERSECTION.
- 5) LATERAL CLEARANCE AT ALL SIGN LOCATIONS SHALL BE 2' AS MEASURED FROM THE EDGE OF PAVEMENT OR THE FACE OF THE CURB. WHEN UNABLE TO OBTAIN THE LATERAL CLEARANCE WITHIN THE MEDIAN AREA USE SHOULDER MOUNTS ONLY.
- 6) SIGN MOUNT LOCATIONS SHALL NOT BLOCK SIDEWALKS OR DRIVEWAYS.
- 7) IF STATIONARY GENERAL WARNING SIGNS ARE USED, THEY WILL BE PAID FOR PER SECTION 104 OF THE NCDOT STANDARD SPECIFICATIONS AS EXTRA WORK.
- 8) IF MILLED AREAS ARE NOT PAVED BACK BY THE END OF THE WORK DAY, PORTABLE SIGNS SHALL BE USED TO WARN DRIVERS OF THE PRESENT CONDITIONS. THESE ARE TO INCLUDE, BUT NOT LIMITED TO "ROUGH ROAD" W8-8, "UNEVEN LANES" W8-11, "GROOVED PAVEMENT" W8-15 w/MOTORCYCLE PLAQUE MOUNTED BELOW. THESE ARE TO BE DOUBLE INDICATED ON MULTI-LANE ROADWAYS WITH SPEED LIMITS 45 MPH AND GREATER WHERE LATERAL CLEARANCE CAN BE OBTAINED WITHIN THE MEDIAN AREAS. THESE PORTABLE SIGNS ARE INCIDENTAL TO THE OTHER ITEMS OF WORK INCLUDED IN THE TEMPORARY TRAFFIC CONTROL (LUMP SUM) PAY ITEM.

LEGEND

- ┆ STATIONARY SIGN
- ➔ DIRECTION OF TRAFFIC FLOW

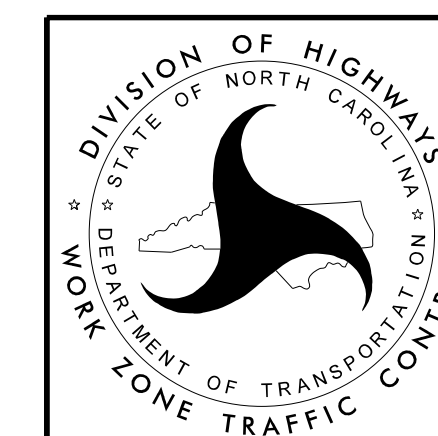

**RESURFACING ADVANCE
WARNING SIGNS FOR
URBAN / SUBURBAN
FACILITIES**

LOGICAL I/O PROCESSOR PROGRAMMING DETAIL TO PRODUCE SPECIAL FYA-PPLT SIGNAL SEQUENCE

(program controller as shown below)

- FROM MAIN MENU PRESS '2' (PHASE CONTROL), THEN '1' (PHASE CONTROL FUNCTIONS). SCROLL TO THE BOTTOM OF THE MENU AND ENABLE ACT LOGIC COMMANDS 1, 2, 3, 4, 5 AND 6.
- FROM MAIN MENU PRESS '6' (OUTPUTS), THEN '3' (LOGICAL I/O PROCESSOR).

LOGICAL I/O COMMAND #1 (+/-COMMAND#)
IF ACTIVE PHASE #1 IS ON
AND RED CLEAR ON PHASE #1 IS ON

SCROLL DOWN

THEN:
SET OUTPUT ASSIGNMENT #50 ON
SET OUTPUT ASSIGNMENT #51 OFF

PRESS '+'

NOTE: LOGIC FOR PHASE 1 RED CLEAR WHEN TRANSITIONING FROM PHASE 1 TO PHASE 2 (HEAD 11).

LOGICAL I/O COMMAND #2 (+/-COMMAND#)
IF ACTIVE PHASE #1 IS ON

SCROLL DOWN

THEN:
SET OUTPUT ASSIGNMENT #52 OFF

PRESS '+'

NOTE: LOGIC FOR SWITCHING FLASHING YELLOW ARROW "OFF" DURING PHASE 1 (HEAD 11).

LOGICAL I/O COMMAND #3 (+/-COMMAND#)
IF YELLOW ON PHASE #1 IS ON

SCROLL DOWN

THEN:
SET OUTPUT ASSIGNMENT #51 ON

PRESS '+'

NOTE: LOGIC FOR YELLOW ARROW CLEARANCE FROM PHASE 1 (HEAD 11).

LOGICAL I/O COMMAND #4 (+/-COMMAND#)
IF ACTIVE PHASE #5 IS ON
AND RED CLEAR ON PHASE #5 IS ON

SCROLL DOWN

THEN:
SET OUTPUT ASSIGNMENT #42 ON
SET OUTPUT ASSIGNMENT #43 OFF

PRESS '+'

NOTE: LOGIC FOR PHASE 5 RED CLEAR WHEN TRANSITIONING FROM PHASE 5 TO PHASE 6 (HEAD 51).

LOGICAL I/O COMMAND #5 (+/-COMMAND#)
IF ACTIVE PHASE #5 IS ON

SCROLL DOWN

THEN:
SET OUTPUT ASSIGNMENT #44 OFF

PRESS '+'

NOTE: LOGIC FOR SWITCHING FLASHING YELLOW ARROW "OFF" DURING PHASE 5 (HEAD 51).

LOGICAL I/O COMMAND #6 (+/-COMMAND#)
IF YELLOW ON PHASE #5 IS ON

SCROLL DOWN

THEN:
SET OUTPUT ASSIGNMENT #43 ON

PRESS '+'

NOTE: LOGIC FOR YELLOW ARROW CLEARANCE FROM PHASE 5 (HEAD 51).

LOGIC I/O PROCESSOR PROGRAMMING COMPLETE

OUTPUT REFERENCE SCHEDULE	
OUTPUT 42	= Overlap C Red
OUTPUT 43	= Overlap C Yellow
OUTPUT 44	= Overlap C Green
OUTPUT 50	= Overlap A Red
OUTPUT 51	= Overlap A Yellow
OUTPUT 52	= Overlap A Green

OVERLAP PROGRAMMING DETAIL

(program controller as shown below)

FROM MAIN MENU PRESS '8' (OVERLAPS), THEN '1' (VEHICLE OVERLAP SETTINGS).

PAGE 1: VEHICLE OVERLAP 'A' SETTINGS
PHASE: 12345678910111213141516
VEH OVL PARENTS: XX
VEH OVL NOT VEH:
VEH OVL NOT PED:
VEH OVL GRN EXT:
STARTUP COLOR: - RED - YELLOW - GREEN
FLASH COLORS: - RED - YELLOW X GREEN
SELECT VEHICLE OVERLAP OPTIONS: (Y/N)
FLASH YELLOW IN CONTROLLER FLASH?...Y
GREEN EXTENSION (0-255 SEC)...0.0
YELLOW CLEAR (0=PARENT,3-25.5 SEC)...0.0
RED CLEAR (0=PARENT,0.1-25.5 SEC)...0.0
OUTPUT AS PHASE # (0=NONE, 1-16)...0.0

← NOTICE GREEN FLASH

PRESS '+' TWICE

PAGE 1: VEHICLE OVERLAP 'C' SETTINGS
PHASE: 12345678910111213141516
VEH OVL PARENTS: XX
VEH OVL NOT VEH:
VEH OVL NOT PED:
VEH OVL GRN EXT:
STARTUP COLOR: - RED - YELLOW - GREEN
FLASH COLORS: - RED - YELLOW X GREEN
SELECT VEHICLE OVERLAP OPTIONS: (Y/N)
FLASH YELLOW IN CONTROLLER FLASH?...Y
GREEN EXTENSION (0-255 SEC)...0.0
YELLOW CLEAR (0=PARENT,3-25.5 SEC)...0.0
RED CLEAR (0=PARENT,0.1-25.5 SEC)...0.0
OUTPUT AS PHASE # (0=NONE, 1-16)...0.0

← NOTICE GREEN FLASH

OVERLAP PROGRAMMING COMPLETE

LOAD RESISTOR INSTALLATION DETAIL

(install resistors as shown below)

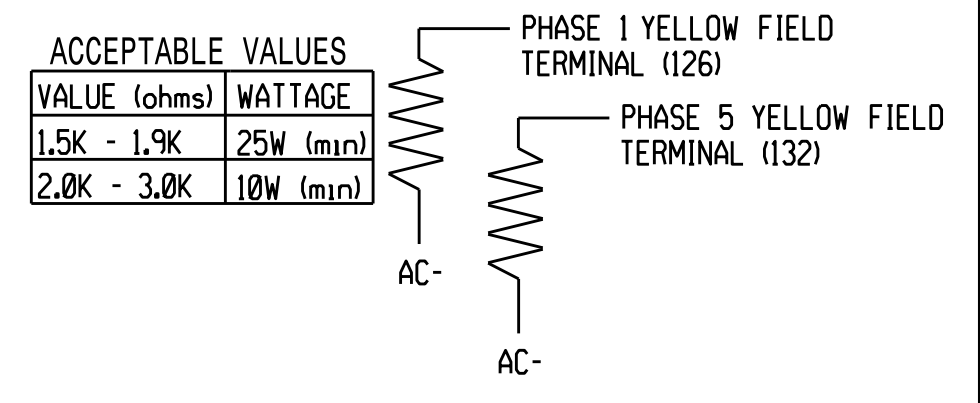

Electrical Detail - Sheet 2 of 3

DOCUMENT NOT CONSIDERED FINAL UNLESS ALL SIGNATURES COMPLETED

Prepared in the Offices of:

750 N. Greenfield Pkwy, Corner, NC 27529

THIS ELECTRICAL DETAIL IS FOR THE SIGNAL DESIGN: 03-0225
DESIGNED: January 2020
SEALED: 1/22/2020
REVISED:

SR 1336 (Henderson Drive)
at
Doris Avenue

Division 3 Onslow County Jacksonville

PLAN DATE: January 2020 REVIEWED BY: T. Joyce

PREPARED BY: C. Strickland REVIEWED BY:

REVISIONS	INIT.	DATE

SEAL

DocuSigned by:
D. Todd Joyce 1/23/2020

SIG. INVENTORY NO. 03-0225

22-UNB-2020_08-31
-M030225_ssm_e1e-xxx.dgn
cestrickland

EMERGENCY VEHICLE PREEMPTION PROGRAMMING DETAIL

(program controller as shown below)

From Main Menu press 'A' (Preemption), then '1' (Standard Preemptions). Press the 'Next' key 2-times to advance to Preempt #3.

EVP 3 :

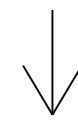

```

PREEMPTION #3 SETTINGS (NEXT:1-10)
INTERVAL/TIMING CLEAR/DWELL PHASES
GRN YEL RED 12345678910111213141516
1 255 0.0 0.0 X X
2 0 0.0 0.0
3 0 0.0 0.0
4 0 0.0 0.0
5 1 0.0 0.0 X X
EXIT CALLS
OPTIONS
PRIORITY (Y/N TO SELECT) .....MED
DELAY TIMER (0-255 SEC) .....0.0
MIN GREEN BEFORE PRE (0= DEFAULT)....1
PED CLEAR BEFORE PRE (0= DEFAULT)....19
YELLOW CLEAR BEFORE PRE (0= DEFAULT).0.0
RED CLEAR BEFORE PRE (0= DEFAULT)....0.0
DWELL MIN TIMER (0-255 SEC) .....10
DWELL MAX TIMER (0=OFF,1-255MIN) ....0
DWELL HOLD-OVER TIMER (0-255) .....0
LATCH CALL? .....N
LINK TO NEXT PREEMPT? .....N
ENABLE BACKUP PROTECTION? .....N
HOLD CLEAR 1 PHASES DURING DELAY? ...N
FAST GREEN FLASH DWELL PHASES? .....N
PED CLEARANCE THROUGH YELLOW? .....Y
INHIBIT OVERLAP GREEN EXTENSION? ...N
SERVICE DURING SOFTWARE FLASH? .....N
REST IN RED DURING DWELL INTERVAL? ..N
FLASH DWELL INTERVAL? .....N
ALLOW PEDS IN DWELL INTERVAL? .....N
RE-TIME DWELL INTERVAL? .....N
OVERLAPS: ABCDEFGHIJKLMNPO
DWELL INT FLASH YELLOW
OMIT OVERLAPS:
    
```

PRESS 'NEXT'

EVP 4 :

```

PREEMPTION #4 SETTINGS (NEXT:1-10)
INTERVAL/TIMING CLEAR/DWELL PHASES
GRN YEL RED 12345678910111213141516
1 255 0.0 0.0 X X
2 0 0.0 0.0
3 0 0.0 0.0
4 0 0.0 0.0
5 1 0.0 0.0 X X
EXIT CALLS
OPTIONS
PRIORITY (Y/N TO SELECT) .....MED
DELAY TIMER (0-255 SEC) .....0.0
MIN GREEN BEFORE PRE (0= DEFAULT)....1
PED CLEAR BEFORE PRE (0= DEFAULT)....19
YELLOW CLEAR BEFORE PRE (0= DEFAULT).0.0
RED CLEAR BEFORE PRE (0= DEFAULT)....0.0
DWELL MIN TIMER (0-255 SEC) .....10
DWELL MAX TIMER (0=OFF,1-255MIN) ....0
DWELL HOLD-OVER TIMER (0-255) .....0
LATCH CALL? .....N
LINK TO NEXT PREEMPT? .....N
ENABLE BACKUP PROTECTION? .....N
HOLD CLEAR 1 PHASES DURING DELAY? ...N
FAST GREEN FLASH DWELL PHASES? .....N
PED CLEARANCE THROUGH YELLOW? .....Y
INHIBIT OVERLAP GREEN EXTENSION? ...N
SERVICE DURING SOFTWARE FLASH? .....N
REST IN RED DURING DWELL INTERVAL? ..N
FLASH DWELL INTERVAL? .....N
ALLOW PEDS IN DWELL INTERVAL? .....N
RE-TIME DWELL INTERVAL? .....N
OVERLAPS: ABCDEFGHIJKLMNPO
DWELL INT FLASH YELLOW
OMIT OVERLAPS:
    
```

PRESS 'NEXT'

EVP 5 :

```

PREEMPTION #5 SETTINGS (NEXT:1-10)
INTERVAL/TIMING CLEAR/DWELL PHASES
GRN YEL RED 12345678910111213141516
1 255 0.0 0.0 X X
2 0 0.0 0.0
3 0 0.0 0.0
4 0 0.0 0.0
5 1 0.0 0.0 X X
EXIT CALLS
OPTIONS
PRIORITY (Y/N TO SELECT) .....MED
DELAY TIMER (0-255 SEC) .....0
MIN GREEN BEFORE PRE (0= DEFAULT)....1
PED CLEAR BEFORE PRE (0= DEFAULT)....19
YELLOW CLEAR BEFORE PRE (0= DEFAULT).0.0
RED CLEAR BEFORE PRE (0= DEFAULT)....0.0
DWELL MIN TIMER (0-255 SEC) .....7
DWELL MAX TIMER (0=OFF,1-255MIN) ....0
DWELL HOLD-OVER TIMER (0-255) .....0
LATCH CALL? .....N
LINK TO NEXT PREEMPT? .....N
ENABLE BACKUP PROTECTION? .....N
HOLD CLEAR 1 PHASES DURING DELAY? ...N
FAST GREEN FLASH DWELL PHASES? .....N
PED CLEARANCE THROUGH YELLOW? .....Y
INHIBIT OVERLAP GREEN EXTENSION? ...N
SERVICE DURING SOFTWARE FLASH? .....N
REST IN RED DURING DWELL INTERVAL? ..N
FLASH DWELL INTERVAL? .....N
ALLOW PEDS IN DWELL INTERVAL? .....N
RE-TIME DWELL INTERVAL? .....N
OVERLAPS: ABCDEFGHIJKLMNPO
DWELL INT FLASH YELLOW
OMIT OVERLAPS:
    
```

PROGRAMMING COMPLETE

Program extend time on optical detector units for 2.0 sec.

22-Jan-2020 09:32
M03025_sen_elec_xxx.dgn
cesir:ck:lam

Electrical Detail - Sheet 3 of 3

THIS ELECTRICAL DETAIL IS FOR
THE SIGNAL DESIGN: 03-0225
DESIGNED: January 2020
SEALED: 1/22/2020
REVISED:

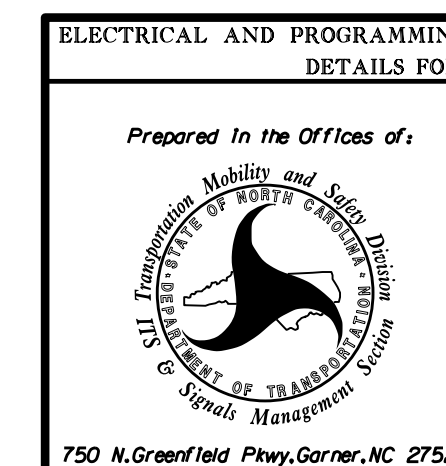

**SR 1336 (Henderson Drive)
at
Doris Avenue**

Division 3 Onslow County Jacksonville

PLAN DATE: January 2020 REVIEWED BY: T. Joyce

PREPARED BY: C. Strickland REVIEWED BY:

REVISIONS	INIT.	DATE

DOCUMENT NOT CONSIDERED
FINAL UNLESS ALL
SIGNATURES COMPLETED

SEAL
NORTH CAROLINA
PROFESSIONAL
ENGINEER
TODD JOYCE
031001

Discussed by: T. Todd Joyce 1/23/2020
DATE

SIG. INVENTORY NO. 03-0225